	INSTALLATION, OPERATION AND MAINTENANCE MANUAL DUAL PLATE CHECK VALVE	DOC NO	CAM-TS-0042
		REV. NO	00
		DATE	15-02-2012
		PAGE NO	1 OF 8

1.0 GENERAL

It is recommended that this entire document shall be read prior to proceeding with the installation or repair. Only correct installation, maintenance and operation will ensure smooth valve operation and maximum life.

CAUTION

Camtech shall not accept any liability if the instructions set forth in this manual are not complied with.

DESIGN CONDITION

- a) Valves are designed and manufactured to be installed in applications where no more than 1g of force in excess of gravity is applied in any direction. This 1g force can be an effect of traffic, wind or Earthquake.
- b) Valve are intended for clean fluid without any specific corrosive, chemical attack or abrasion presents please get the recommendation for such application if abrasion presents.

1.1 RESPONSIBILITY FOR VALVE SELECTION AND APPLICATION

Due to the variety of duties on which the product can be employed, it is the end users responsibility to ensure the compatibility of the media with the valve rating and materials of construction of the product for each specific application (i.e. corrosion, erosion and wear which may affect the integrity of the pressure containing parts. Camtech may offer suggestions in the selection but the selection process is solely the responsibility of plant designers. Plant designers should take into account the specific effects that the process media will have on the valve wall thickness and corresponding service life and ensure that the selected material is corresponding with the process media.



Warning: The user is advised that misapplication of the product may result in injuries or property damage.

2.0 HEALTH AND SAFETY

2.1 When installing and maintaining valves

- a.) Conduct a risk assessment and eliminate or reduce hazards.
- b.) Work in accordance with safe systems of work.
- c.) Observe all site health and safety rules, and in conformity with the legal local company specific instructions on occupational health and safety and prevention of accidents
- d.) Valve shall only be operated by personnel qualified by training/experience.
- e.) Certain processes utilize flammable, Caustic or unstable media. Care should be taken in these circumstances to ensure that the operator is aware of the specific health and safety risks associated with that media.
- f.) If the process or environments that the products are used in are likely to cause temperatures (high or low) that may cause injury to personnel if touched, then adequate insulation/protection must be fitted.



Warning: Non observance of safety instructions and warning may provoke risks of personnel injury and damage to the valves or damage to the equipment and pollution or damage to the environment

PREPARED BY : D.K	CHECKED BY : K.M.P	APPROVED BY : G.M.R
-------------------	--------------------	---------------------

	INSTALLATION, OPERATION AND MAINTENANCE MANUAL DUAL PLATE CHECK VALVE	DOC NO	CAM-TS-0042
		REV. NO	00
		DATE	15-02-2012
		PAGE NO	2 OF 8

 **Warning:** Do not exceed the maximum operating conditions specified in the name plate. Non observance of this warning may cause personnel injury and damage to property like injuries resulting from fluid leakage (cold, hot toxic, under pressure) and impairment of valve function.

3.0 PRESERVATION, SHIPMENT AND HANDLING

3.1 All valves are properly packed in order to protect the parts that are subject to deterioration during transportation and storage on site. Valve ends are protected with suitable plastic or wooden caps. The packing are appropriate to ensure safe transportation, protect the valves against external forces such as impacts, and vibration. During handling use appropriate tools like brackets, hook, fastener, ropes, etc. respecting the load capacity as appropriate.

CAUTION

1. Do lift the valve through proper lifting hooks provided or with ropes and slings.
2. Caution must be taken during the handling to avoid that this equipment passes over the workers or over any others place where a possible fall could have cause damage. In any case, the local safety regulations must be followed.

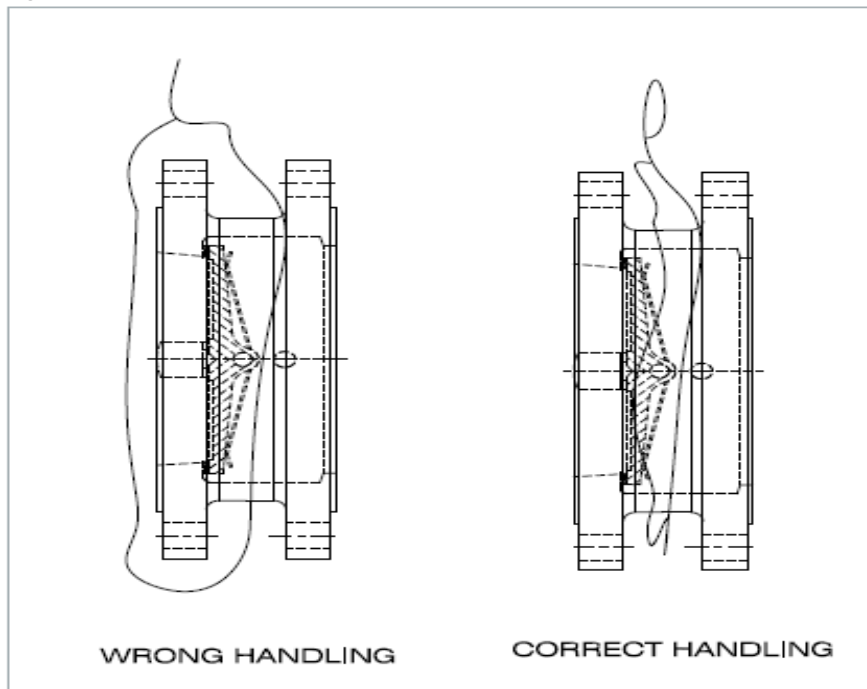

4.0 STORAGE

- a.) Store the valve in closed dry rooms on solid ground in a dirt-free atmosphere. Allow the valves to remain in their original protective packings.
- b.) Do not place the consignment packages directly on the ground.
- c.) Do not expose consignment packages to the weather or directly to the sun.
- d.) Check the paint coating for damage and corrosion at regular intervals.
- e.) Check the packaging every two months.
- f.) Repair the protective coating if necessary.

PREPARED BY : D.K	CHECKED BY : K.M.P	APPROVED BY : G.M.R
-------------------	--------------------	---------------------

	INSTALLATION, OPERATION AND MAINTENANCE MANUAL DUAL PLATE CHECK VALVE	DOC NO	CAM-TS-0042
		REV. NO	00
		DATE	15-02-2012
		PAGE NO	3 OF 8

5.0 MARKING

Valves are provided with 1 nameplate

MFR STANDARD		 
PN / CLASS / SIZE		
● MATERIAL		
MOP @ M / MOT		
SERIAL No. / DATE		

6.0 INSTALLATION

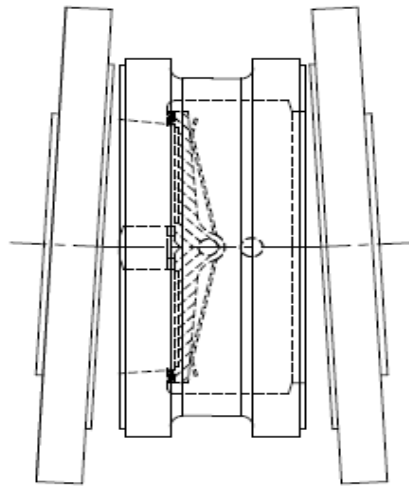

WRONG INSTALLATION

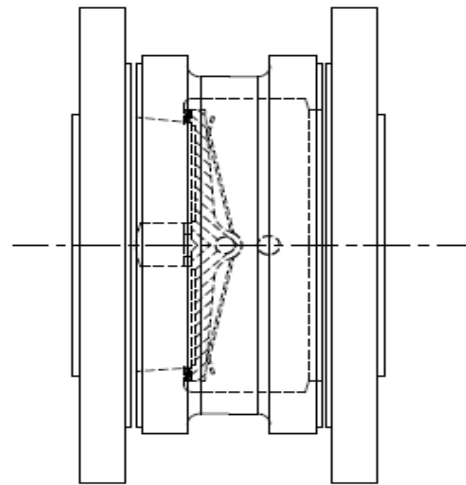

CORRECT INSTALLATION

6.1 PREPARATION BEFORE INSTALLATION

1. As a rule, the engineering contractor, Construction Company or operator/user is responsible for the positioning and installation of the valves. Planning and installation errors may impair the reliable function of the valves and pose a substantial safety hazard.
2. Confirm that the materials of construction of the valve, and the maximum pressure / temperature specified in the nameplates are appropriate for the service intended and are as specified.
3. Thoroughly clean adjacent piping system to remove any foreign material, weld, pieces of wood/plastic, repair the defect which are caused during the transportation.
4. Verify that the space available for installation is adequate to allow the valve to be installed and to be operated.
5. Clean thoroughly the accessible interior spaces of body ends, surfaces and functional parts.

PREPARED BY : D.K	CHECKED BY : K.M.P	APPROVED BY : G.M.R
-------------------	--------------------	---------------------



INSTALLATION, OPERATION AND MAINTENANCE MANUAL DUAL PLATE CHECK VALVE

DOC NO	CAM-TS-0042
REV. NO	00
DATE	15-02-2012
PAGE NO	4 OF 8

6. Check valves is normally installed horizontally in vertical or horizontal pipelines.
7. Pay special attention to the flow direction when installing the valve, the flow direction shall be the same as the arrow marked on the valve body, otherwise will cut the flow required.
8. Valve shall not be used at the end of the pipe line.
9. When the check valve is closing, the water hammer pressure will emerge, it will be too serious to cause damage to the valve, pipeline or equipment, specially for big size or high pressure. User shall pay highly attention to valve selection.
10. After installing the valve in the pipeline, clean the pipeline with clean water, remove possible residue during the installation in order to protect the sealing surface from being scratched.

THE FOLLOWING PROVISIONS SHALL BE MADE IN THE PIPELINE

- a) Dangerous discharge of pressure relief blow off.
- b) Appropriate measure in the pipeline due to decomposition of unstable fluids where exist. Operator shall have thorough knowledge of such fluids and operate the valve as per established documented instructions.
- c) Pressure relief valve, where unexpected increase in pressure, water hammer is anticipated and allowable pressure limit can be exceeded.
- d) Valves are not provided with filling or discharge. Such provisions where required shall be provided in the pipeline.

6.2 VALVE INSTALLATION

1. Install the valve as per the flow direction.
2. Support the valve and adjacent pipelines, such that pipeline thrust and torsional forces are not transmitted to the valve.

A. WAFER / LUGGED / FLANGED VALVES

1. Clean the flange faces to ensure that it is free from damage.
2. The gaskets on the mating flanges are properly centered. Only fasteners and gaskets of approved materials shall be used. Place the valve between the two flanges of the pipe and put the gasket between the valve flanges and the pipe flange. Make sure that it is correctly positioned. Tighten the flange bolts progressively and crosswise. Use torque wrench to tighten to the requested torque specified by the specification. Ensure that the flanges are straight and aligned to the pipe.

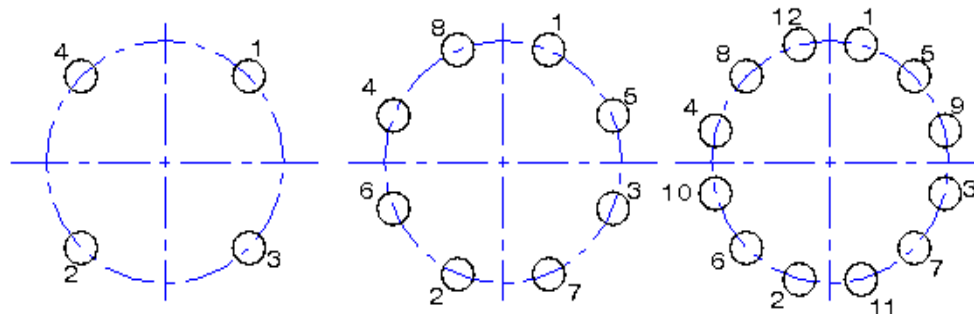

Bolt Tightening Sequence

PREPARED BY : D.K

CHECKED BY : K.M.P

APPROVED BY : G.M.R

FORMAT NO :- 04-01-F12 REV.NO: 00 DATE:- 01-02-2012

	INSTALLATION, OPERATION AND MAINTENANCE MANUAL DUAL PLATE CHECK VALVE	DOC NO	CAM-TS-0042
		REV. NO	00
		DATE	15-02-2012
		PAGE NO	5 OF 8

B. BUTT WELD VALVES

Position the valve and align with the pipe. Remove any grease or protective paint that may have been applied to the weld ends. Use the smallest electrodes and the minimum amperage possible consistent with approved welding procedures. This will help to minimize warpage in the seat areas. Valves of carbon steel should be allowed to cool slowly. The valve may be covered with a heat insulating blanket to promote slow cooling and limit the heat affected zone. Follow ASME standards and industry standards.

7.0 OPERATION

1. Do not use Check valves in any direction. Check valves are unidirectional valve. Hence check for the preferred flow direction mark.
2. Retighten all the bolts / nuts.
3. Subject the valve to the required pressure and temperature gradually and slowly.
4. Ensure that there is no leak from the valve and the operation is smooth.

7.1 USE OF CHECK VALVES

Check valves are used for back pressure / back flow to the pumps, turbines, etc. this allows flow in only one direction and stops the flow from other side.

7.2 SHUT DOWN

Close the valve. De pressure and drain/vent all fluids. Allow the valve to cool down. Remove any electric connector before maintenance. Follow the process guide lines.

7.3 EXAMINATION OF VALVES

Periodically examine the valve depending on the fluid condition and criticality. As a minimum annual examination of shell thickness and valve condition shall be made depending upon the fluid.

8.0 MAINTENANCE



WARNING:

Before starting any maintenance, depressurize, drain and vent and flushed with air. Check that the valves are not in temperature. Disconnect any electrical power supply. Failure to do so may cause serious personnel injury and/or equipment damage.

PREPARED BY : D.K	CHECKED BY : K.M.P	APPROVED BY : G.M.R
-------------------	--------------------	---------------------



INSTALLATION, OPERATION AND MAINTENANCE MANUAL DUAL PLATE CHECK VALVE

DOC NO	CAM-TS-0042
REV. NO	00
DATE	15-02-2012
PAGE NO	6 OF 8

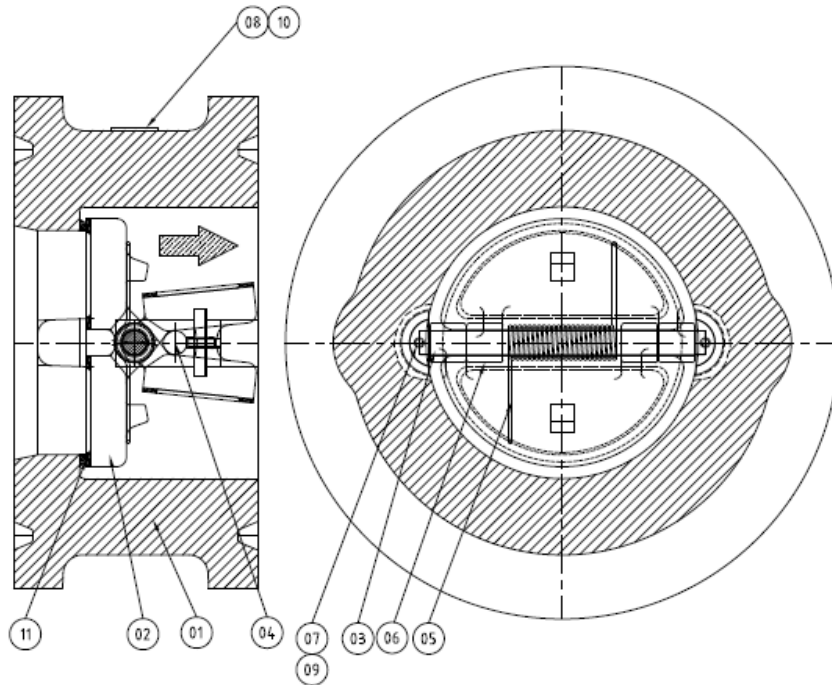

No.	PART NAME
01	BODY
02	DISC
03	HINGE PIN
04	STOP PIN
05	SPRING
06	BEARING
07	BEARING LOCK
08	NAME PLATE
09	GRUB SCREW
10	RIVET
11	BODY SEAT

8.1 PREVENTIVE MAINTENANCE

All valve components have been designed to be largely maintenance free. The material of the moving parts has been selected for minimum wear. However malfunction caused by wrong operation, lack of maintenance or improper use reduces valve life. All repair and maintenance work shall be performed by qualified personnel following all safety instructions. Maintenance intervals should be selected by the valve user in compliance with the application condition.

9.0 TROUBLE SHOOTING

TROUBLE	POSSIBLE CAUSE	HOW TO ELIMINATE
No fluid flow	Flange covers not removed. Valve installed in wrong direction. Pipeline upstream of valve is blocked.	Clean the valve. The flow direction shall be as per the flow direction or as shown in the above figure. Clean or replace strainer/ other blocking equipment. Inspect the pipeline.

PREPARED BY : D.K

CHECKED BY : K.M.P

APPROVED BY : G.M.R

FORMAT NO :- 04-01-F12 REV.NO: 00 DATE:- 01-02-2012

	INSTALLATION, OPERATION AND MAINTENANCE MANUAL DUAL PLATE CHECK VALVE	DOC NO	CAM-TS-0042
		REV. NO	00
		DATE	15-02-2012
		PAGE NO	7 OF 8

Flow Rate not sufficient	Valve is not full open. Sediments inside the valve. Dirty strainer.	Clean the valve. Clean or replace strainer/other blocking equipment. Inspect the pipeline.
Valve is leaking	Valve is not firmly closed. Excessive differential pressure. Seat and DISC seat faces damages. Excessive load from the pipeline.	Check the system. Remachine/lap seat faces.

10.0 VALVE DISASSEMBLY AND ASSEMBLY

VALVE DISASSEMBLY

Follow the following steps to disassemble the valve.

A. HINGE PIN ASSEMBLY

1. Loosen and remove grub screw (09)
2. Lift the bearing block (07) from the body
3. Remove the hinge pin (03) along with disc assembly (02),(05),(06)

B. DISC (02)

1. Remove the DISC assembly from hinge pin (03)

VALVE ASSEMBLY

Follow reverse sequence of disassembly and assemble the valve

11.0 GREASES AND SPECIAL TOOLS

The following greases or equivalent other make can be used for bearing
 BEACON 2 ESSO, MOBILELUX EP2 MOBL, ALVANIAR2 SUPER GREASE SHELL, MULTIFAK EP2 GREASE,

SPECIAL TOOL

No Special tool is required for the maintenance.

12. RECOMMENDED SPARES

There is no spare part applicable for the dual plate check valve.

PREPARED BY : D.K	CHECKED BY : K.M.P	APPROVED BY : G.M.R
-------------------	--------------------	---------------------

	INSTALLATION, OPERATION AND MAINTENANCE MANUAL DUAL PLATE CHECK VALVE	DOC NO	CAM-TS-0042
		REV. NO	00
		DATE	15-02-2012
		PAGE NO	8 OF 8

For Explosive atmosphere, following precautions/measures shall be taken.

1.0 Maximum Surface Temperature

Valves do not generate energy / temperature on its own. The maximum surface temperature do not depends upon the valve, but on the operating fluid condition. The maximum operating fluid temperature is limited as per ASME B 16.34. However for explosive atmosphere, where the surface temperature due to operating fluid is potential source of explosion, provide insulation / other appropriate measures.

2.0 Bearing lubrication

Bearings are slow moving parts and do not require lubrication. However lubrication is provided for smooth operation.

3.0 Dust deposit

Remove dust at regular intervals for explosive atmosphere. Ensure that dust do not present in the gaps and outside surfaces to exclude the possibility of explosion. Ensure that the surroundings are clean and no external part fall on the surface.

PREPARED BY : D.K	CHECKED BY : K.M.P	APPROVED BY : G.M.R
-------------------	--------------------	---------------------