	INSTALLATION, OPERATION AND MAINTENANCE MANUAL CONDUIT GATE VALVE	DOC NO	CAM-TS-0039
		REV. NO	00
		DATE	10-03-2012
		PAGE NO	1 OF 10

1.0 GENERAL

It is recommended that this entire document shall be read prior to proceeding with the installation or repair. Only correct installation, maintenance and operation will ensure smooth valve operation and maximum life.

CAUTION

Camtech shall not accept any liability if the instructions set forth in this manual are not complied with.

DESIGN CONDITION

- a) Valves are designed and manufactured to be installed in applications where no more than 1g of force in excess of gravity is applied in any direction. This 1g force can be an effect of traffic, wind or Earthquake.
- b) Valve are intended for clean fluid without any specific corrosive, chemical attack or abrasion presents please get the recommendation for such application if abrasion presents.

1.1 RESPONSIBILITY FOR VALVE SELECTION AND APPLICATION

Due to the variety of duties on which the product can be employed, it is the end users responsibility to ensure the compatibility of the media with the valve rating and materials of construction of the product for each specific application (i.e. corrosion, erosion and wear which may affect the integrity of the pressure containing parts. Camtech may offer suggestions in the selection but the selection process is solely the responsibility of plant designers. Plant designers should take into account the specific effects that the process media will have on the valve wall thickness and corresponding service life and ensure that the selected material is corresponding with the process media.



Warning: The user is advised that misapplication of the product may result in injuries or property damage.

2.0 HEALTH AND SAFETY

2.1 When installing and maintaining valves

- a.) Conduct a risk assessment and eliminate or reduce hazards.
- b.) Work in accordance with safe systems of work.
- c.) Observe all site health and safety rules, and in conformity with the legal local company specific instructions on occupational health and safety and prevention of accidents
- d.) Valve shall only be operated by personnel qualified by training/experience.
- e.) Certain processes utilize flammable, Caustic or unstable media. Care should be taken in these circumstances to ensure that the operator is aware of the specific health and safety risks associated with that media.
- f.) When operating manual valves, gloves should be worn to minimize the risk of injury to the hands/skin due to high temperature/ low temperature valve body.
- g.) When operating any valve stand clear of any moving parts such as the stem and/ or operator moving parts.

PREPARED BY : D.K	CHECKED BY : K.M.P	APPROVED BY : G.M.R
-------------------	--------------------	---------------------



INSTALLATION, OPERATION AND MAINTENANCE MANUAL CONDUIT GATE VALVE

DOC NO	CAM-TS-0039
REV. NO	00
DATE	10-03-2012
PAGE NO	2 OF 10

h.) If the process or environments that the products are used in are likely to cause temperatures (high or low) that may cause injury to personnel if touched, then adequate insulation/protection must be fitted.

 **Warning:** Non observance of safety instructions and warning may provoke risks of personnel injury and damage to the valves or damage to the equipment and pollution or damage to the environment

 **Warning:** Do not exceed the maximum operating conditions specified in the name plate. Non observance of this warning may cause personnel injury and damage to property like injuries resulting from fluid leakage (cold, hot toxic, under pressure) and impairment of valve function.

3.0 PRESERVATION, SHIPMENT AND HANDLING

3.1 All valves are properly packed in order to protect the parts that are subject to deterioration during transportation and storage on site. The valves are packed with the slab in the closed position. Valve ends both flanged and buttweld ends are protected with suitable plastic or wooden caps. The packing are appropriate to ensure safe transportation, protect the valves against external forces such as impacts, and vibration. During handling use appropriate tools like brackets, hook, fastener, ropes, etc. respecting the load capacity as appropriate.

CAUTION

1. Do not lift the valve through hand wheel, eye bolt or actuator.
2. Caution must be taken during the handling to avoid that this equipment passes over the workers or over any others place where a possible fall could have cause damage. In any case, the local safety regulations must be followed.

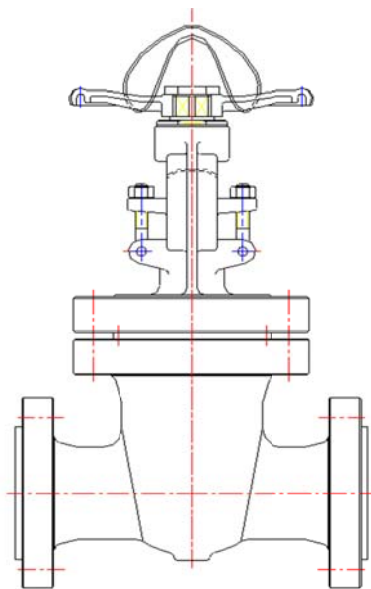

WRONG HANDLING

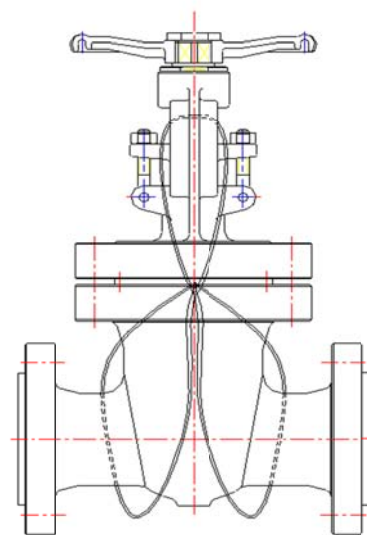

CORRECT HANDLING

PREPARED BY : D.K

CHECKED BY : K.M.P

APPROVED BY : G.M.R

FORMAT NO :- 04-01-F12 REV.NO: 00 DATE:- 01-02-2012



	INSTALLATION, OPERATION AND MAINTENANCE MANUAL CONDUIT GATE VALVE	DOC NO	CAM-TS-0039
		REV. NO	00
		DATE	10-03-2012
		PAGE NO	3 OF 10

4.0 STORAGE

- a.) Store the valve in closed dry rooms on solid ground in a dirt-free atmosphere. Allow the valves to remain in their original protective packings.
- b.) Do not place the consignment packages directly on the ground.
- c.) Do not expose consignment packages to the weather or directly to the sun.
- d.) Check the paint coating for damage and corrosion at regular intervals.
- e.) Check the packaging every two months.
- f.) Repair the protective coating if necessary.

5.0 MARKING

Valves are provided with 1 nameplate

MFR STANDARD		 
PN / CLASS / SIZE		
● MATERIAL		
MOP @ M / MOT		
SERIAL No. / DATE		

6.0 INSTALLATION

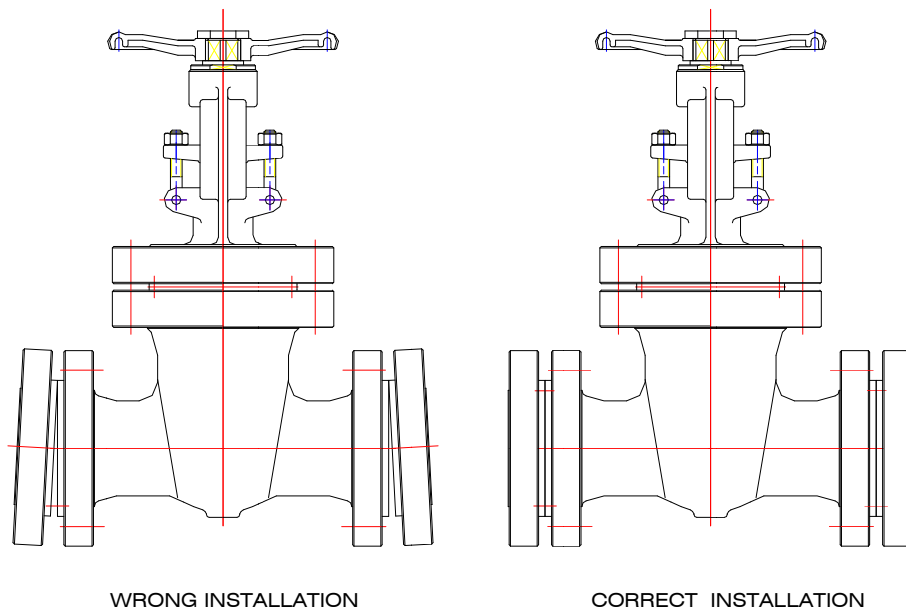

PREPARED BY : D.K	CHECKED BY : K.M.P	APPROVED BY : G.M.R
-------------------	--------------------	---------------------

	INSTALLATION, OPERATION AND MAINTENANCE MANUAL CONDUIT GATE VALVE	DOC NO	CAM-TS-0039
		REV. NO	00
		DATE	10-03-2012
		PAGE NO	4 OF 10

6.1 PREPARATION BEFORE INSTALLATION

1. As a rule, the engineering contractor, Construction Company or operator/user is responsible for the positioning and installation of the valves. Planning and installation errors may impair the reliable function of the valves and pose a substantial safety hazard.
2. Confirm that the materials of construction of the valve, and the maximum pressure / temperature specified in the nameplates are appropriate for the service intended and are as specified.
3. Thoroughly clean adjacent piping system to remove any foreign material, weld, pieces of wood/plastic.
4. Verify that the space available for installation is adequate to allow the valve to be installed and to be operated.
5. Clean thoroughly the accessible interior spaces of body ends, surfaces and functional parts and mounting parts (stem, flange for actuator, mounting etc.)
6. Conduit Gate valves can be installed normally in horizontal pipelines with vertical stem and with flow from either direction.
7. Valve shall not be used at the end of the pipe line.

THE FOLLOWING PROVISIONS SHALL BE MADE IN THE PIPELINE

- a) Draining and venting. Valves are provided with plugs for draining and venting. Drilled , tapped and plugged connections for draining and venting are provided for all valves.
- b) Dangerous discharge of pressure relief blow off.
- c) Appropriate measure in the pipeline due to decomposition of unstable fluids where exist. Operator shall have thorough knowledge of such fluids and operate the valve as per established documented instructions.
- d) Pressure relief valve, where unexpected increase in pressure, water hammer is anticipated and allowable pressure limit can be exceeded.
- e) Valves are not provided with filling or discharge. Such provisions where required shall be provided in the pipeline.

6.2 VALVE INSTALLATION

1. Install the valve with slab in the closed position.
2. Support the valve and adjacent pipelines, such that pipeline thrust and torsional forces are not transmitted to the valve.

A. FLANGED VALVES

1. Clean the flange faces to ensure that it is free from damage.
2. The gaskets on the mating flanges are properly centered. Only fasteners and gaskets of approved materials shall be used. Place the valve between the two flanges of the pipe and put the gasket between the valve flanges and the pipe flange. Make sure that it is correctly positioned. Tighten the flange bolts progressively and crosswise. Use torque wrench to tighten to the requested torque specified by the specification. Ensure that the flanges are straight and aligned to the pipe.

PREPARED BY : D.K	CHECKED BY : K.M.P	APPROVED BY : G.M.R
-------------------	--------------------	---------------------

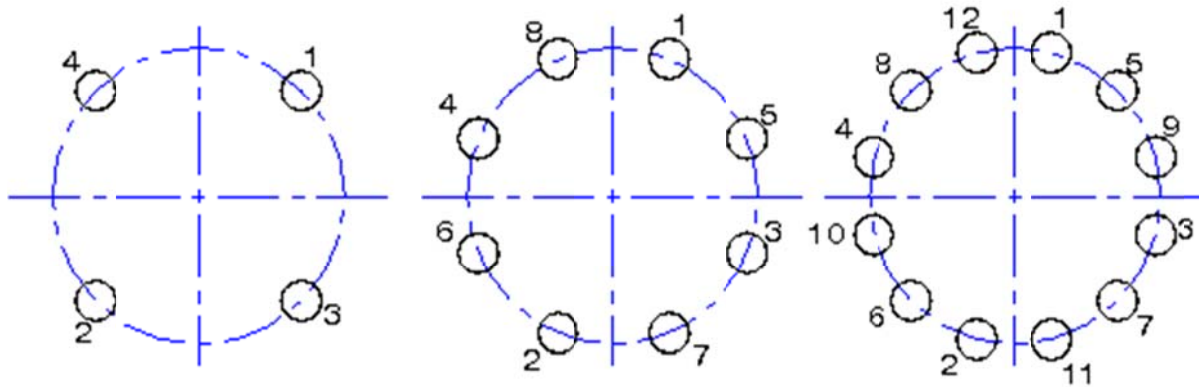

Bolt Tightening Sequence

B. BUTT WELD VALVES

Position the valve and align with the pipe. Remove any grease or protective paint that may have been applied to the weld ends. Use the smallest electrodes and the minimum amperage possible consistent with approved welding procedures. This will help to minimize warpage in the seat areas. Valves of carbon steel should be allowed to cool slowly. The valve may be covered with a heat insulating blanket to promote slow cooling and limit the heat affected zone. Follow ASME standards and industry standards.

C. VALVE VERIFICATION BEFORE START-UP

1. Tighten the packing just enough to prevent stem leakage. Over tightening will decrease packing life and increase operating torque.
2. Check the operation of the valve by stroking it to full open and full close.

7.0 OPERATION

1. Valves are closed by turning the hand wheel in clockwise direction and opened by turning in counter clockwise direction.
2. Do not use gate valves for throttling operation. Valves shall be either in full open or full close position.
3. Subject the valve to the required pressure and temperature gradually and slowly.
4. Retighten all bolts/nuts including the stuffing box gland. Clean and degrease the stem.
5. Ensure that there is no leak from the valve and the operation is smooth.

7.1 USE OF GATE VALVES

Gate valves are used for on-off service. Gate valve shall not be used for throttling operation. Valve shall be opened/closed slowly and gradually to the position.

	INSTALLATION, OPERATION AND MAINTENANCE MANUAL CONDUIT GATE VALVE	DOC NO	CAM-TS-0039
		REV. NO	00
		DATE	10-03-2012
		PAGE NO	6 OF 10

7.2 SHUT DOWN

Close the valve. De pressure and drain/vent all fluids. Allow the valve to cool down. Remove any electric connector before maintenance. Follow the process guide lines.

7.3 EXAMINATION OF VALVES

Periodically examine the valve depending on the fluid condition and criticality. As a minimum annual examination of shell thickness and valve condition shall be made depending upon the fluid.

8.0 MAINTENANCE

a. PACKING MAINTENANCE

If leakage is observed through the packing, tighten the gland nuts slowly and evenly until the leakage stops. Use half-turn increment for tightening.

CAUTION

Do not over tighten packing gland nuts. Over tightening will increase the torque required to operate the valve and reduce packing life.

PACKING REPLACEMENT



WARNING:

Before starting any maintenance, depressurize, drain and vent and flushed with air. Check that the valves are not in temperature. Disconnect any electrical power supply.

Failure to do so may cause serious personnel injury and/or equipment damage.

1. Open completely the valve up to the backseat position
2. Remove the nuts (21) of the yoke bolt.
3. Remove the yoke (03) and gear box assembly (22) / hand wheel assembly.
4. Remove the gland (10) by turning it and remove it completely from the stem.
5. Remove the worn-out packing using a hocking wire/other device. Clean the stem and stuffing box bore.
6. Repack the packing rings at a time and ensure that they are fitted correctly and against the bottom.
7. Replace the gland (10) and re-tighten it, replace the yoke (03) in their original position
8. Cycle the valve. Pressurize the line
9. If the leakage occurs, tighten the gland nuts slowly and evenly until the leakage stops.

b. BODY – BONNET FLANGE GASKET MAINTENANCE



WARNING:

Before starting any maintenance, depressurize, drain, vent and flush with air the line. Check that the valves are not in temperature: Disconnect any electrical Power supply. Failure to do so may cause personal injury and or/equipment damage.

PREPARED BY : D.K	CHECKED BY : K.M.P	APPROVED BY : G.M.R
-------------------	--------------------	---------------------



INSTALLATION, OPERATION AND MAINTENANCE MANUAL CONDUIT GATE VALVE

DOC NO	CAM-TS-0039
REV. NO	00
DATE	10-03-2012
PAGE NO	7 OF 10

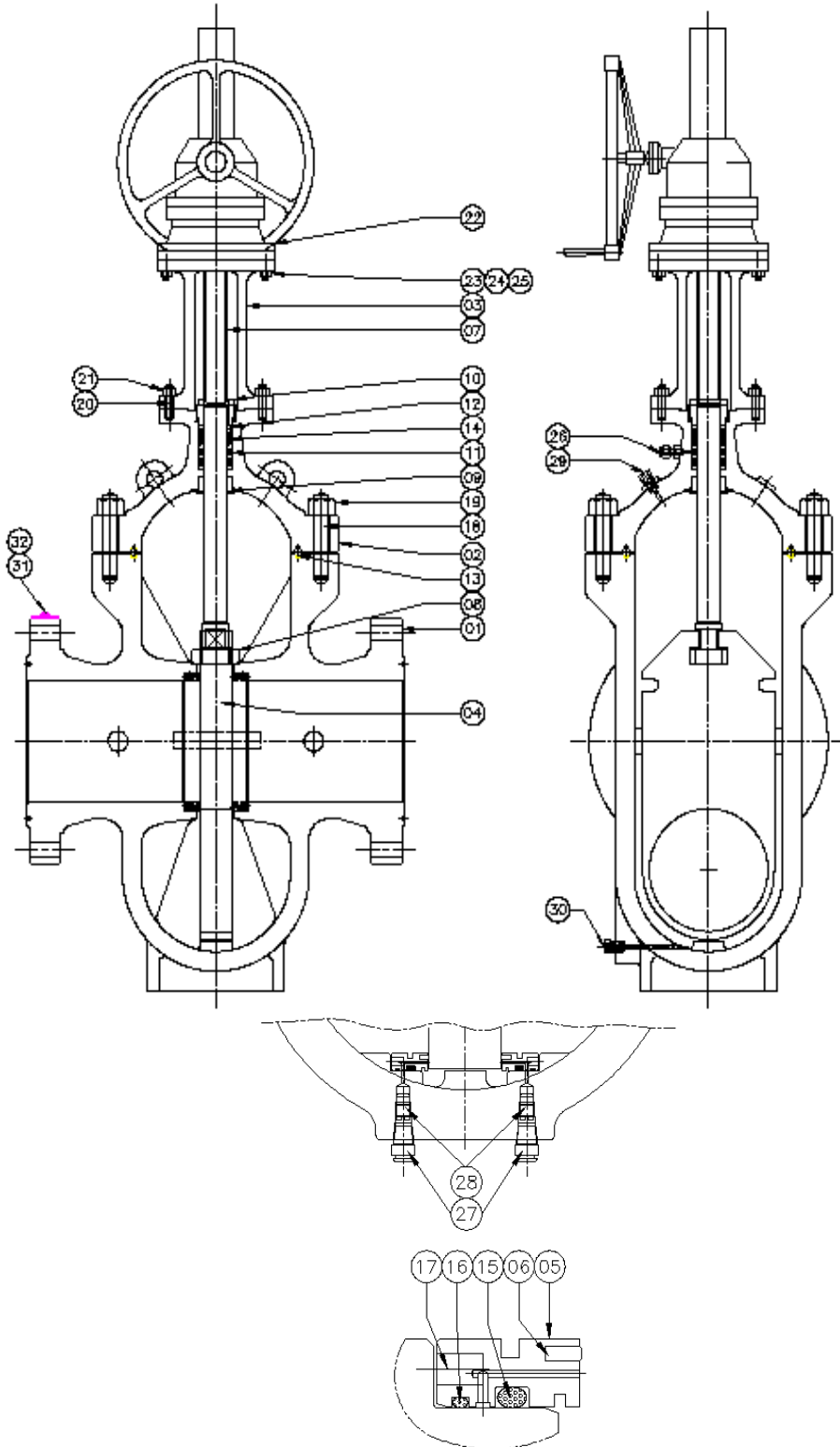

No.	PART NAME
01	BODY
02	BONNET
03	YOKE
04	SLAB
05	SEAT RING
06	SEAT INSERT
07	STEM
08	STOPPER
09	BACK SEAT BUSH
10	GLAND
11	LANTERN RING
12	PACKING RING
13	BONNET GASKET
14	PACKING
15	'O' RING
16	'O' RING
17	SPRING
18	STUD (BODY)
19	NUT (BODY)
20	STUD (YOKE)
21	NUT (YOKE)
22	GEAR BOX
23	STUD (GEAR BOX)
24	NUT (GEAR BOX)
25	SPRING WASHER (GEAR BOX)
26	SEALANT INJECTOR (STEM)
27	SEALANT INJECTOR (SEAT)
28	NRV (SEAT)
29	VENT PLUG
30	DRAIN PLUG
31	NAME PLATE
32	RIVET

PREPARED BY : D.K

CHECKED BY : K.M.P

APPROVED BY : G.M.R



INSTALLATION, OPERATION AND MAINTENANCE MANUAL CONDUIT GATE VALVE

DOC NO	CAM-TS-0039
REV. NO	00
DATE	10-03-2012
PAGE NO	8 OF 10

1. Clean the flange surface
2. Place the gasket in its seat position the bonnet in correct position. Ensure that gasket is not shifted from the correct position.
3. Position all the studs/nuts
4. Tighten the stud/nut uniformly, gradually and crosswise.
5. Follow the bolt tightening sequence. Follow the tightening torque given.
6. After equipment is installed and pressured tighten once again all the bolts.

1. Bolt tightening Torque

Nominal bolt size (inch)	Torque (Nm)	Nominal bolt size (inch)	Torque (Nm)
1/2"	80	1 3/8"	1780
5/8"	160	1 1/2"	2300
3/4"	275	1 5/8"	3000
7/8"	440	1 3/4"	3700
1"	650	1 7/8"	4700
1 1/8"	950	2"	5700
1 1/4"	1300		

2. Valve Torque and Mounting of actuator

The valve torque depends upon many parameters like size, class, maximum operating pressure, frequency of operation, fluid details, viscosity and flow velocity. Please contact camtech, who selects the optimum size of actuator and supply of mounting plates for field conversion.

8.1 PREVENTIVE MAINTENANCE

All valve components have been designed to be largely maintenance free. The material of the moving parts has been selected for minimum wear. However malfunction caused by wrong operation, lack of maintenance or improper use reduces valve life. All repair and maintenance work shall be performed by qualified personnel following all safety instructions. Maintenance intervals should be selected by the valve user in compliance with the application condition.

PREPARED BY : D.K

CHECKED BY : K.M.P

APPROVED BY : G.M.R

	INSTALLATION, OPERATION AND MAINTENANCE MANUAL CONDUIT GATE VALVE	DOC NO	CAM-TS-0039
		REV. NO	00
		DATE	10-03-2012
		PAGE NO	9 OF 10

9.0 TROUBLE SHOOTING

TROUBLE	POSSIBLE CAUSE	HOW TO ELIMINATE
No fluid flow	Flange covers not removed. Valve in closed position. Pipeline upstream of valve is blocked.	Open the valve. Clean the valve. Clean or replace strainer/other blocking equipment. Inspect the pipeline
Flow Rate not sufficient	Valve is not full open. Sediments inside the valve. Dirty strainer.	Open the valve. Clean the valve. Clean or replace strainer/other blocking equipment. Inspect the pipeline.
Valve is leaking	Valve is not firmly closed. Excessive differential pressure. Seat and wedge seat faces damages. Excessive load from the pipeline.	Close the valve. Check the system. Remachine/lap seat faces.
Valve cannot be operated or it is difficult to open/close	Operating condition might be outside the specification. Bent shaft or thread damaged Valve cavity clogged.	Check the line/Valve. Check and replace worn/bent parts.

10.0 VALVE DISASSEMBLY AND ASSEMBLY

VALVE DISASSEMBLY

Follow the following steps to disassemble the valve.

A. BONNET ASSEMBLY

1. Loosen and remove the nut (19)
2. Lift the bonnet assembly (02) from the body
3. Remove the bonnet gasket (13)

B. SLAB (04)

1. Remove the slab (04) from the stem (07)

C. STEM

1. Remove the hand wheel / gear box nut (24).
2. Remove the hand wheel / gear box (22) from the stem (07)
3. Loosen the gland (10)

PREPARED BY : D.K	CHECKED BY : K.M.P	APPROVED BY : G.M.R
-------------------	--------------------	---------------------

	INSTALLATION, OPERATION AND MAINTENANCE MANUAL CONDUIT GATE VALVE	DOC NO	CAM-TS-0039
		REV. NO	00
		DATE	10-03-2012
		PAGE NO	10 OF 10

4. Pull the stem downwards and remove it from the bonnet.
5. Remove the packing (12) from the bonnet(02) and place on clean surface.

VALVE ASSEMBLY

Follow reverse sequence of disassembly and assemble the valve

11.0 GREASES AND SPECIAL TOOLS

The following greases or equivalent other make can be used for bearing/stem/nut/gearboxes/stem
BEACON 2 ESSO, MOBILELUX EP2 MOBL, ALVANIAR2 SUPER GREASE SHELL, MULTIFAK EP2 GREASE,

SPECIAL TOOL

No Special tool is required for the maintenance.

12. RECOMMENDED SPARES

- Gland packing (12)
- Bonnet gasket (13)
- Note : Only Camtech supplied spares shall be used

For Explosive atmosphere, following precautions/measures shall be taken.

1.0 Maximum Surface Temperature

Valves do not generate energy / temperature on its own. The maximum surface temperature do not depends upon the valve, but on the operating fluid condition. The maximum operating fluid temperature is limited as per ASME B 16.34. However for explosive atmosphere, where the surface temperature due to operating fluid is potential source of explosion, provide insulation / other appropriate measures.

2.0 Projected stem

Ensure that the projected stem do not touch any piping or other part that can create spark.

3.0 Bearing lubrication

Bearings are slow moving parts and do not require lubrication. However lubrication is provided for smooth operation.

4.0 Dust deposit

Remove dust at regular intervals for explosive atmosphere. Ensure that dust do not present in the gaps and outside surfaces to exclude the possibility of explosion. Ensure that the surroundings are clean and no external part fall on the surface.

- 5.0 Valves are not provided with any opening or enclosure for explosion prevention.

PREPARED BY : D.K	CHECKED BY : K.M.P	APPROVED BY : G.M.R
-------------------	--------------------	---------------------